



LFP 12.8V60 HBT

Rechargeable Lithium Iron Phosphate Battery



LiFePO₄

PRODUCT FEATURES



• **Super Safe Lithium Iron Phosphate Chemistry.**



• **High Performance and Durability:** Offers significantly longer cycle life compared to traditional lead-acid batteries, ensuring reliable performance in a wide temperature range from -20°C to 60°C.



• **Faster Charging and Lower Self-Discharge:** Outperforms lead-acid batteries in both areas.



• **Compact and Lightweight:** High energy density in a small, lightweight design, ideal for space and weight-sensitive applications.



• **Long Lifespan:** Over 15 years of stable, maintenance free performance.



• **Unique Built-In BMS:** Monitors and controls battery parameters, providing protection against over-charging, over-discharging, over-current, and short circuits.



• **Bluetooth Connectivity:** Displays the battery's state of charge (SOC) and operating status.



• **Heat Film:** Ensures reliable performance in low-temperature environments.

FUNCTIONAL SPECIFICATIONS

Cell Chemistry :	LiFePO ₄
Cell Type :	Prismatic
Nominal Voltage :	12.8V
Nominal Capacity :	60Ah
Stored Energy :	768Wh
Internal Resistance :	≤15mΩ
Self-Discharge per Month :	<2%
Cycle life @ 80% DOD :	3500Cycles*
Series Connection :	4 Units
Parallel Connection :	4 Units
Combination Mode :	4S1P(3.2V, 63Ah)
Communication Interface :	Bluetooth

MECHANICAL SPECIFICATIONS

Dimensions (L*W*H/TH) :	228*138*208/212 mm
Weight :	7.5±0.2 Kg
Terminal Type :	M6
Case Material :	ABS
Ingress Protection Marking :	IP65

CHARGE SPECIFICATIONS

Recommended Charge Voltage :	≤14.6V
Recommended Charge Current :	≤15A (0.25C)**
Max. Charge Current :	≤60A
Over Voltage Protection :	15±0.2V
Reconnect Voltage :	14.2V
Primary Charge Current Protection :	120±10A/10±3s

DISCHARGE SPECIFICATIONS

Recommend Discharge Current :	≤30A (0.5C)**
Max. Discharge Current :	≤60A/250A,2s
Max. Discharge Voltage :	≥10.4V
Low Voltage Protection :	8.8±0.4V
Reconnect Voltage :	10.4±0.4V
Primary Discharging Current Protection :	120±10A/10±3s
Short Circuit Protection :	1320±150A/<500 μs

ENVIRONMENTAL SPECIFICATIONS

Charge Temperature :	-20~45°C
Discharge Temperature :	-20~60°C
Storage Temperature :	-10~40°C
Optimal Operation Humidity :	5~95% RH/Non-condense

OUTLINE DIMENSION

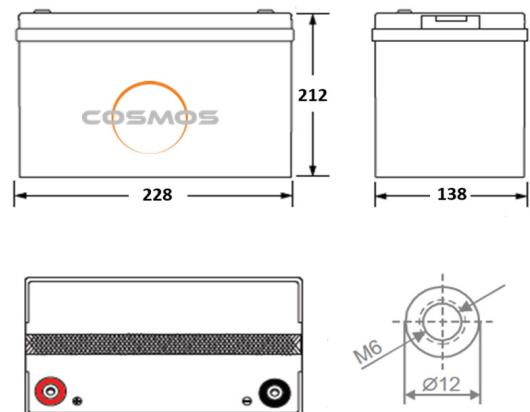

*Refer to warranty terms for cycle life performance conditions

** C=Capacity

Discharge Performance (25°C)

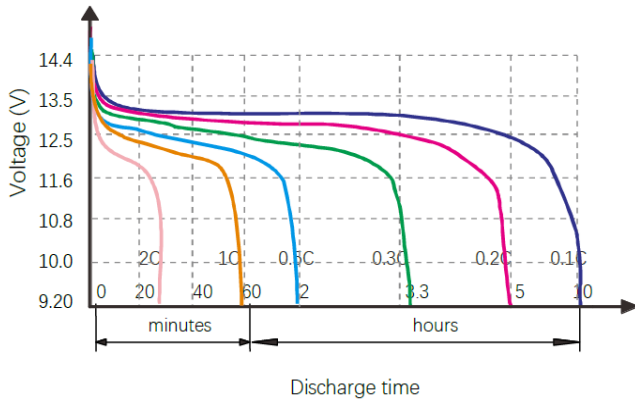

Temperature Impact on Discharge Performance (0.5C)

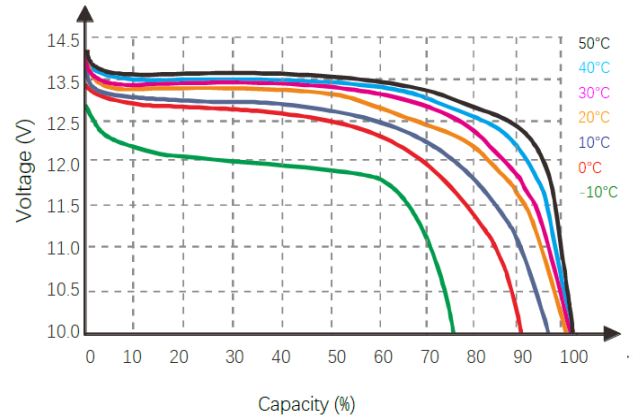

State of Charge Curve (25°C)

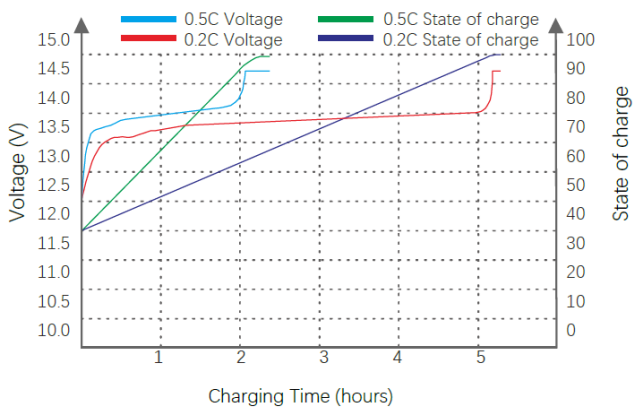

Charge Characteristics (25°C)

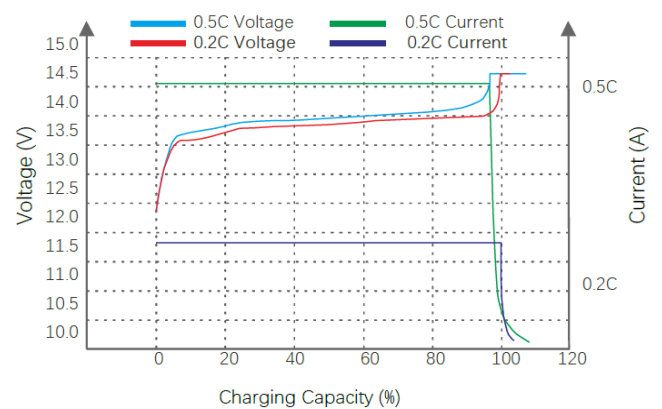

Cycle life in relation to Depth of Discharge (0.2C)(25°C)

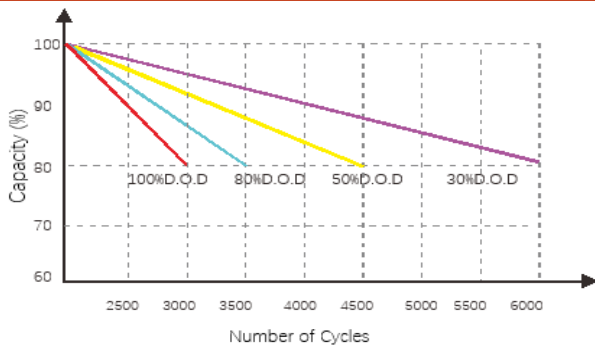

Self-Discharge Characteristics

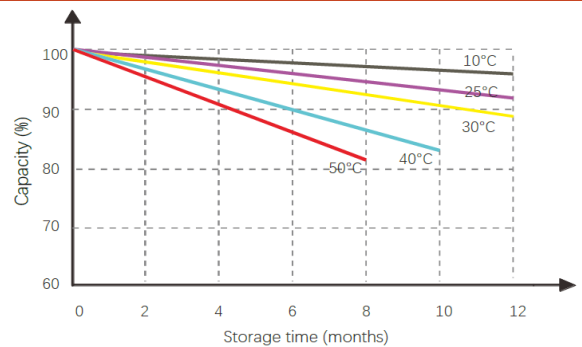

APPLICATIONS



- Renewable Energy Storage
- Recreational Vehicles (RVs)
- Small Electric Vehicles (EVs)
- Backup Power Systems
- Portable Power Packs
- Emergency Lighting and Equipment
- Marine Applications
- Remote Monitoring and Telemetry

CERTIFICATIONS

- UN38.3
- CE
- RoHS

SHIPPING CLASSIFICATION

- UN 3480
- Class 9