

LFP 80-12 (LiFePO4)

12,8V / 80Ah

The COSMOS lithium Series is the definitive choice for a wide variety of markets; Solar and Renewable Energy Storage; Electric Vehicle and Golf cart; Industrial equipment; Floor Machines; Robotics; Marine and UPS systems.

FEATURES:

- Long service life / Long cycle life
- Low self-discharge
- Less weight than lead acid batteries
- Excellent performance in all operation temperatures
- Built-in BMS (Battery Management System)
- Unique QR-coding on each battery
- Batteries don't require much servicing to prolong its service life

Technical Specifications

Lithium Chemistry	: LiFePO4
Rated Nominal Voltage	: 12,8V
Nominal Capacity	: 80Ah
Nominal Rated Energy	: 1024 Wh
Design Life (Float Application)	: 15 yrs
Cycle Life (0.2C, 25°C)	: 6000* (*tested on cell level)
Overall Duty Efficiency	: 99,50%
Number of cells per block	: 4
- Number of strings per block	: 1
- Number of cells per string	: 4
Maximum Series Blocks	: 4
Maximum Parallel strings	: 4
Communications Protocols (if applicable)	: No (optional)
Heater installed	: No (optional)

Mechanical Specifications

Dimensions (L x W x H)	: 260x169x211 mm
Weight	: 9.8kg
Terminal Type	: M8
Terminal Torque Recommendation	: 12.4 Nm
Case Material	: ABS
IP Class	: IP50

Charging Information

	<i>See also BMS Parameters</i>
Charging Voltage Range	: 14.6~14.8V
Float Voltage Range	: 13.6~13.8V
Max. constant current	: 100A

Discharging Information

	<i>See also BMS Parameters</i>
Cut-off Voltage	: 8.8V
Max. constant current	: 100A
Max. peak current	: 420A

Storage/Operating Temperatures

	<i>See also BMS Parameters</i>
Storage	: -20~45 °C
Discharge	: -23~65 °C
Charge	: -3~65 °C



APPLICATIONS:

- Telecom
- Stand-By
- Energy Storage
- Light scooters
- Patient Lifts
- Small Industrial Applications
- RV's / Leisure
- Boats / Nautical
- All light cyclic applications

SAFETY STANDARD:

- UN38.3

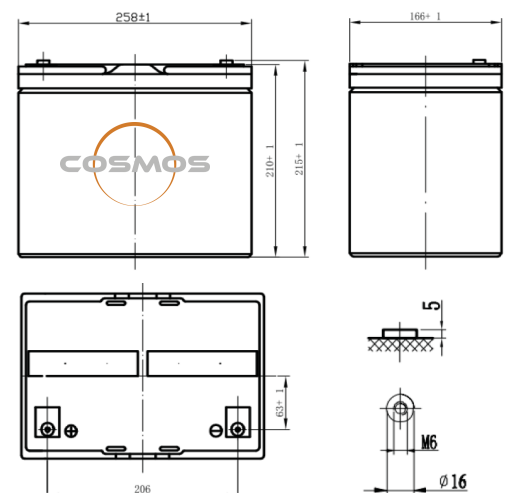

LFP 80-12 (LiFePO4)

12,8V / 80Ah



BMS PARAMETERS

NO.	Type		Function	Setting Value	Remarks	
				Model		
1	Voltage	Charge	Cell Voltage Protection	3.75V Protection	Recover at 3.5V	
2			Total Voltage Protection	15.0V Protection	Recover at 14.0V	
3		Discharge	Cell Voltage Protection	2.3V Protection	Recover at 2.7V	
4			Total Voltage Protection	9.2V Protection	Recover at 10.8V	
5	Current	Charge	Normal	$\leq 100A$	-	
6			Over Current Protection 1	130A	Delay 10s, recovery in every 1 min	
7			Over Current Protection 2	-	-	
8		Discharge	Normal	$\leq 50A$	-	
9			Over Current Protection 1	200A	Delay 30s, recovery in every 1 min	
10			Over Current Protection 2	$\geq 200A$ and $\leq 500A$	Delay 2s,	
11			Short Circuit Protection	$\geq 750A$	Delay 1ms	
12		Temp	Cell Temp 1	Low Temp Protection	Charging $\leq 0^{\circ}C$ Discharging $\leq -20^{\circ}C$	Delay 1 ~ 2s
13			Cell Temp 2	High Temp Protection	Charging $\geq 60^{\circ}C$ Discharging $\geq 70^{\circ}C$	Delay 1 ~ 2s
14			PCB	Range	$\geq 95^{\circ}C$	Recovery at $75^{\circ}C$

STATE OF CHARGE

Different DOD Discharge Cycle Life Curve 1C 25C

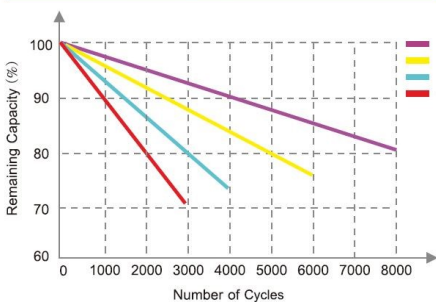

Different Temperature Discharge Curve(0.2C)

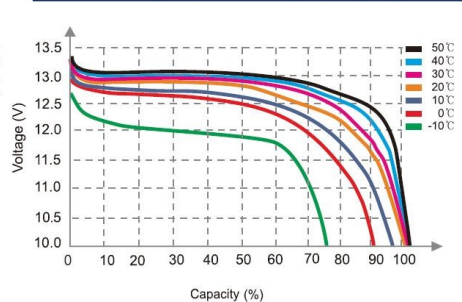

State of Charge Curve(0.5C, 25°C)

